

PROCESS GAS SOLUTIONS

Screw compressors and positive displacement blowers for applications in the process gas industry



AERZEN

AERZEN. PREMIUM GRADE IN EVERY PROCESS.



Discover the difference.

The differences in compressor technologies can be found right where the demanding applications are. Where often highly critical processes gases and coolants are compressed. In the chemical, petrochemical, energy, food, or pharmaceutical industries. The demands on plant design, engineering, documentation and worldwide service in those industries are often just as high as the safety and environmental guidelines to be followed.

For over 150 years, AERZEN has been developing a unique expertise for these industries. Beginning with Europe's first rotary lobe compressor, which we developed in 1868. Our history has given rise to a unique knowledge pool of technological advances and know-how. And we have focused it primarily on our PGD centre – the AERZEN Process Gas Division.

Made by AERZEN, made in Germany.

There is nothing that creates more pressure than our own expectations, and at AERZEN we want to provide our clients with the best possible solutions. Advanced blowers and compressors for the process gas and coolant industries. Unbeatable in their quality. Inspiring in their longevity, reliability, and accessibility. Precise in their adaptation to client process requirements – with the result that they are revolutionary in their efficiency.

This is why we are on hand for you in over 100 countries around the world – because proximity to our clients is important to us. This is why we work hard to understand all the unique features of your applications until we understand them in every detail. And this is probably the reason why our blowers, our oil-free and oil-injected compressors are among the market leaders. And why the name AERZEN has become synonymous for premium technology “made in Germany”.



CONTENTS

APPLICATIONS	4
INDUSTRIES	6
ENGINEERING	8
VR OIL-FREE SREW COMPRESSORS	12
VMY OIL-INJECTED AND OIL-FREE SCREW COMPRESSORS	14
GQ/GR PROCESS GAS BLOWERS	16
GM HIGH-PRESSURE BLOWERS	18
PRODUCTS	20
SERVICES	24

KEY APPLICATIONS. SOMETIMES CRITICAL. ALWAYS DEMANDING.

Chemical and Petrochemical Industries

- Compression of H₂ and CH mixtures
- Acetylene
- Ethylenes
- Lime kiln gas
- Rich gas
- Synthesis raw gas
- Butadiene
- Vinyl chloride
- Hydrogen sulphide
- Hydrogen

Refineries

- Hydrocracking
- Hydrosulphurisation
- Fractionating
- Reforming
- Catalytic cracking
- PSA
- Flare gas
- Compression of H₂ and CH mixtures

Energy production

- Gas turbine supply
- Steam

Oil & Gas Conveyance and Storage

- VOC recovery
- Natural gas compression
- Pipeline booster
- Underground gas storage

Industrial gases

- Hydrogen generation
- Air separation
- Argon
- Syngas

Coolant industry

- Coolants (R1270, R290, etc.)

Helium Refrigerator and Liquefier

- Helium

Offshore

- Natural gas compression

Breweries

- Waste steam

Pharmaceuticals

Coking plants



Gas supply



Chemical industry



Power station technology



“PROCESS GAS COMPRESSORS AND BLOWERS FROM AERZEN FUNCTION RELIABLY IN ALL INDUSTRIES, IN ALL MARKETS, AND IN ALL COUNTRIES ON EARTH.”

INDUSTRIES AND SECTORS. COMPRESSION UNDER ALL CONDITIONS.

AERZEN offers the process gas and coolant industries an incredibly broad spectrum of blower and compression technologies – perhaps the broadest of any manufacturer. Machines that operate as stand-alones, in machine or container combinations, onshore and offshore. In every single key industrial application.

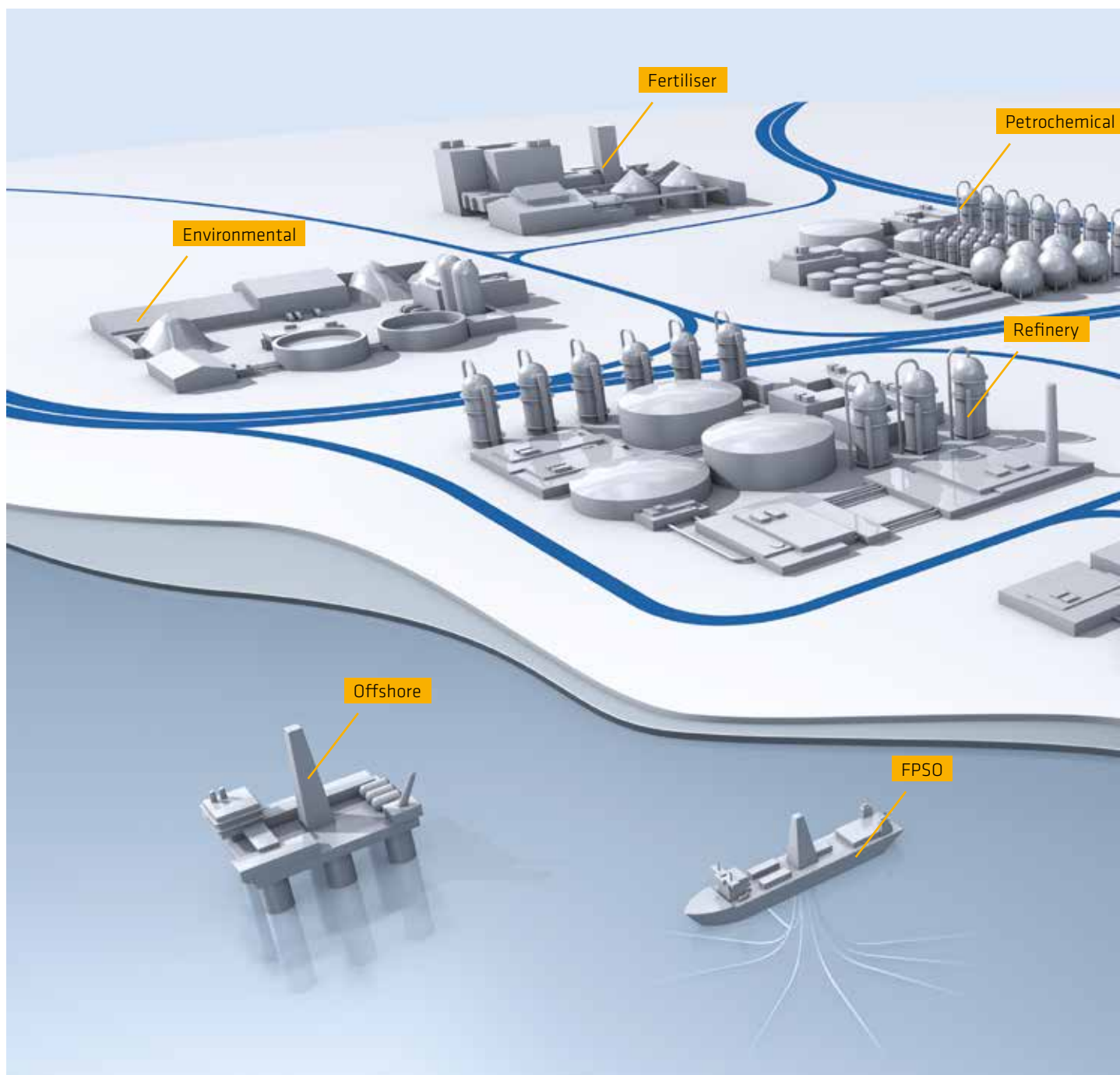

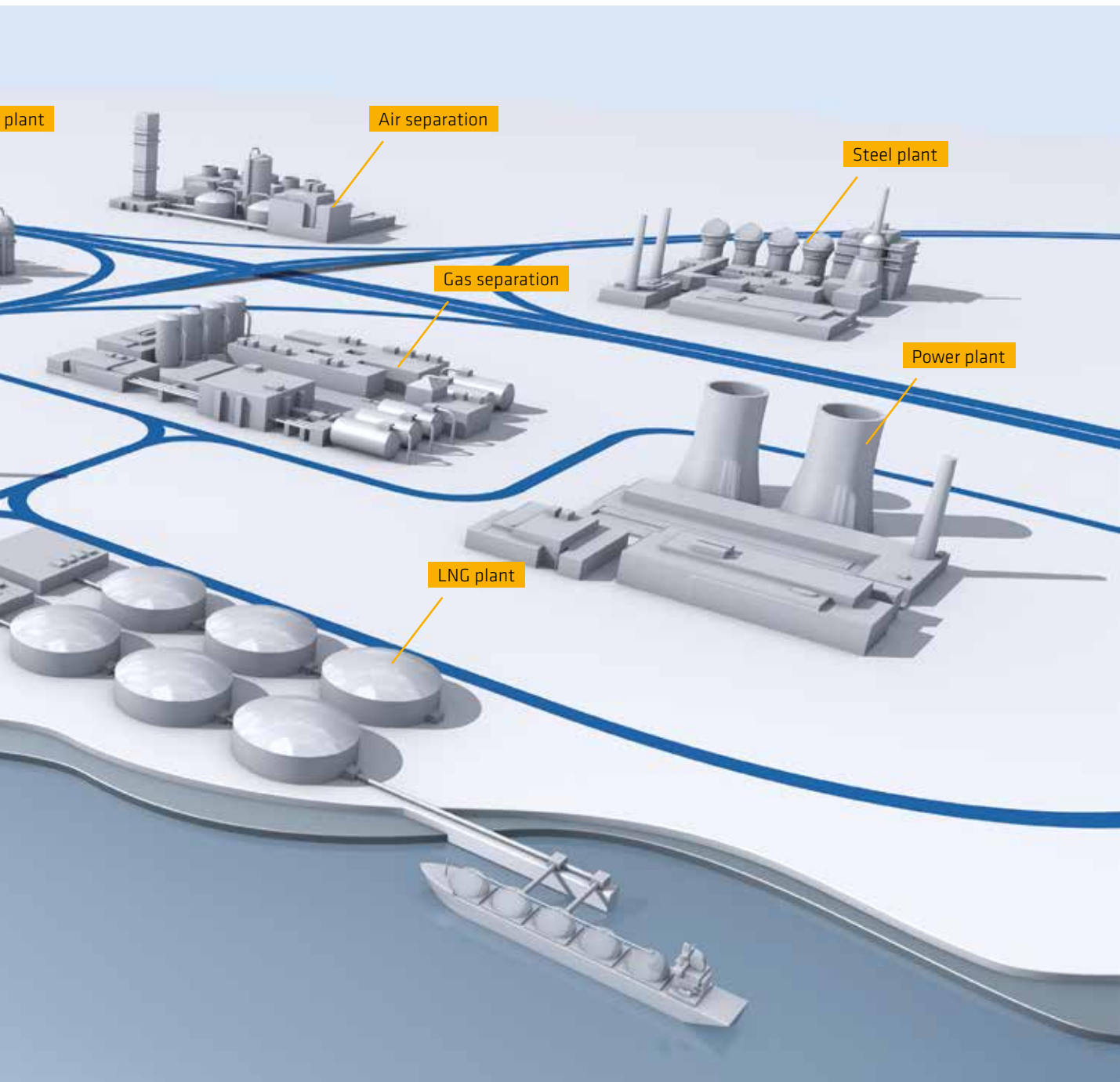

ENGINEERING. FROM APPLICATIONS TO HIGH-END SOLUTIONS.

It is not the machine that determines the process – it is the process that determines the machine. This is our philosophy. Anyone as application-oriented as AERZEN invests heavily in groundwork. The kind that results in a solid understanding of the client’s business. The kind that forms the basis for the high-performance solutions that come from our design forge. State-of-the-art technologies for the most demanding process gas and coolant applications.

Understanding the process.

The philosophy and technical design underlying process gas and coolant facilities demand a high level of intelligence. After all, they are expected to work in the world’s most demanding industries. Often in highly critical applications. That is why AERZEN has gathered together its best minds in the Process Gas Division. A team of excellently trained specialists from construction, instrumentation, control, and project management. With international experience in all areas of process gas compression and transport. They operate in Germany, Hungary, and the USA. For markets and industries the world over.

Design forge AERZEN.

Our process gas and coolant compressors are designed, constructed, and tested according to certified design processes and DIN ISO 9001. In Germany – in the town of Aerzen, to be precise. AERZEN’s entire technical expertise is focused on our engineering and production centre. This is where our R&D work happens. All the engineering. From construction to measurement, control and electronic technologies. And that’s where we ensure that the high quality of our solutions can go into serial production – even if they’re way beyond the standard.



The engineering process at AERZEN is supported by modern software tools



The engineering teams in Germany, Hungary and the USA are closely networked





“AERZEN HAS GATHERED TOGETHER SOME OF ITS BEST MINDS IN THE PROCESS GAS DIVISION - IN ALL AREAS OF PROCESS GAS COMPRESSION AND CONVEYANCE.”

Premium. In every phase of the project.

Our PGD is developing and constructing compressor and blower stages for process gas applications, as well as tailor-made units. Demanding technologies that can satisfy clients' individual requirements. That is our strength. And underlying that strength is AERZEN's technical competence as a producer of blowers and oil-free and oil-injected compressors. Along with an extraordinary breadth of knowhow and performance. Our engineering teams stay with the project through all phases of facilities development - from the first on-site inspection to well after final commissioning. They assume responsibility for the project in all areas of system design - from project management and coordination to quality control and system integration, documentation and certification, packaging and shipping, maintenance and service. This is how we ensure that our turnkey solutions also meet the demand for the highest possible quality - a demand that comes from AERZEN itself.

Smart minds. Intelligent technologies.

The engineering process in our home base in Aerzen is based on decades of experience. And on modern software tools: state-of-the-art development and design technologies such

as AutoCAD Mechanical or Inventor which ensure accurate plans for facilities designs. Flow charts, lists and tables are created in Engineering Base, process calculations with UNISYM. Special programmes are used for the raw performance data and FEM calculations. All these tools help ensure clear 3D visualisation, precise materials lists, and transparent coordination with the client. By the way: all AERZEN machines are also tested in Aerzen - in our own testing facilities.

Engineering services from AERZEN

- Process data calculations (drive performance, coolant requirements)
- Preparation of drive dimensioning start-up curves
- Acoustic calculations
- Torsion and critical bending calculations
- Pipeline calculations (including earthquake calculations)
- Consultation for all client safety concerns (e.g. HAZOP studies)
- Re-engineering (constructive, electrotechnical)

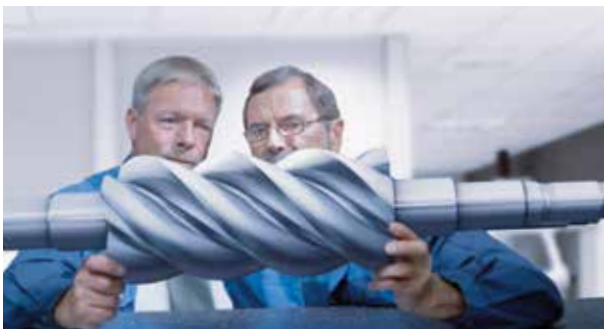

At AERZEN, experience and the inventive spirit go hand in hand



Up-to-date computer programs in the service of our design engineers





“EVERY SOLUTION FROM AERZEN IS INDIVIDUALISED.
TAILORED TO OUR CLIENTS’ SPECIFIC REQUIREMENTS.
THAT’S OUR STRENGTH.”

VR PROCESS GAS COMPRESSORS. ALL PROCESSES. ALMOST NO LIMITATIONS.

They were developed for the dry compression of almost all gases. From ammonia and argon to styrene, vinyl chloride or hydrogen. The only limitations are pressure and temperature ranges and allowable rotational speeds. The VR series has an enormous application range. For final pressures up to 53 bar.

The hallmarks of efficiency.

Large pressure differentials, combined with volumetric efficiency rates: that is what differentiates AERZEN VR compressors from other rotary lobe machines that also operate according to the displacement principle with internal compression. A special 4+6 rotary profile brings this plus in efficiency to process gas applications. The highly available VR compressors can be designed as either single stage or multistage. With variable drive types such as direct drive or helical gearing. Flanged or mounted separately. And in principle designed with the conveying direction from top to bottom – an important prerequisite for fluid injection, which is often necessary in cases of highly contaminated or polymerising gases.

Performance and characteristics.

- Technology: oil-free positive-pressure and negative-pressure compressor units and stages
- Volume flow: 650 to 120,000 m³/h
- Negative pressure: -900 mbar; positive pressure 52 bar (g)
- Rotors: 4+6 profile
- Media: air, as well as neutral, toxic, flammable, or corrosive gases or gas mixtures

Intake volume flow Q_1 (m³/h)

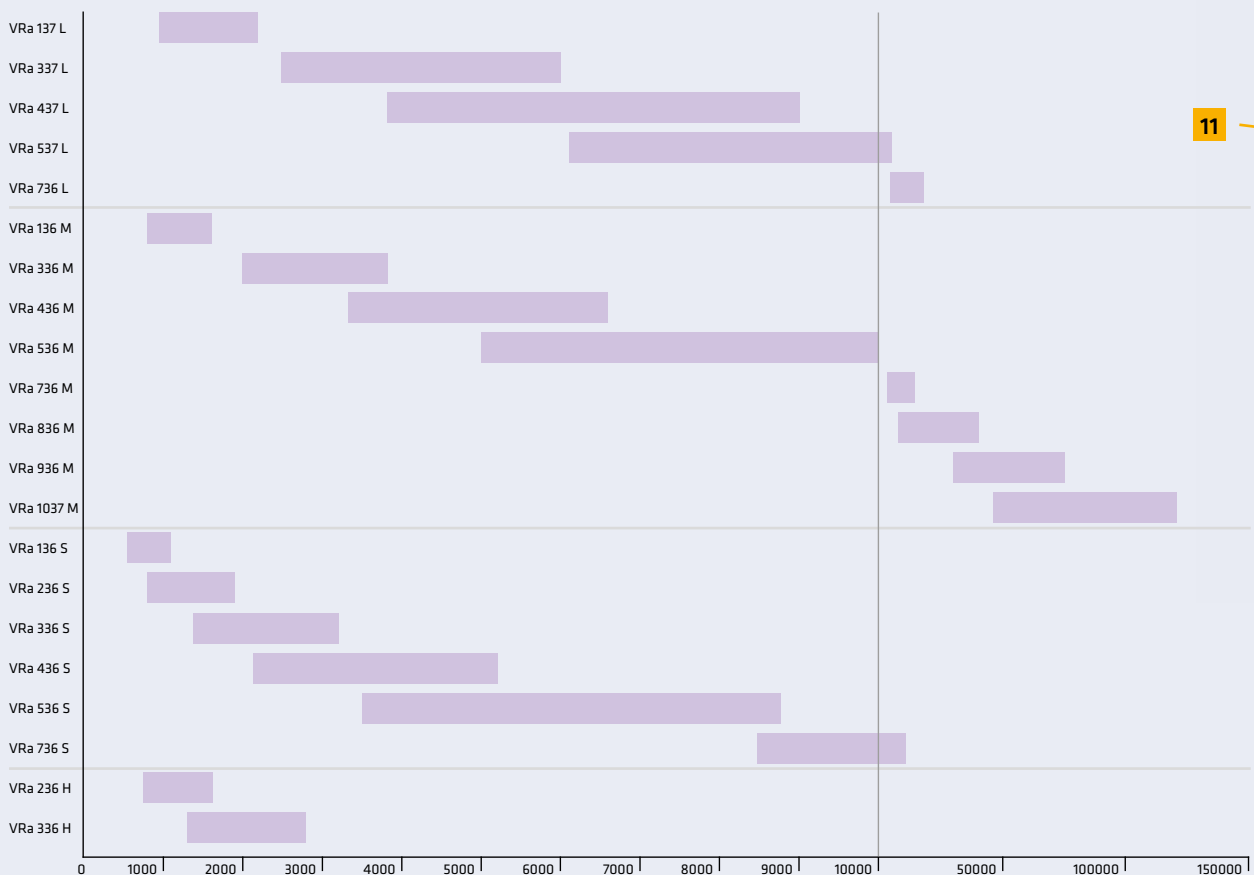

6

11

12

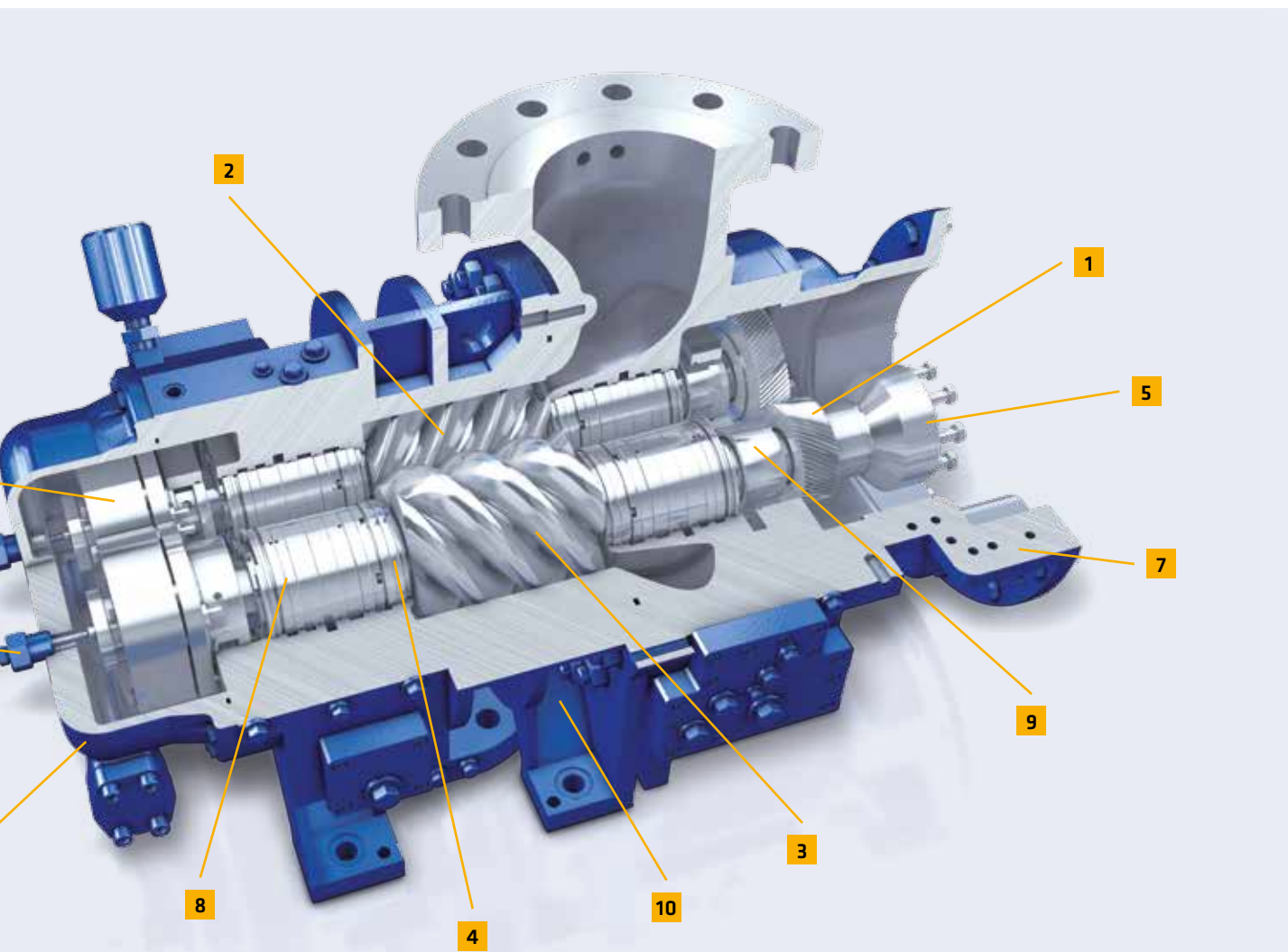

VR process gas compressor.

- | | | | |
|-----------------------|-------------------------|-----------------------------------|--------------------------------|
| 1 Gear pair | 4 Labyrinth seal | 7 Intermediate plate drive | 10 Housing |
| 2 Female rotor | 5 Coupling hub | 8 Mechanical seal | 11 Axial thrust sensors |
| 3 Male rotor | 6 Axial bearings | 9 Radial bearing | 12 Housing lid |

VMY PROCESS GAS COMPRESSOR. THE BEST SOLUTION FOR VARIABLE VOLUME STREAMS.

Compressors in the VMY series have built their reputation in closed cooling circuits. Demonstrated their great efficiency in open process systems (chemistry, petro chemistry, energy production), and proven themselves in closed-loop cooling systems. They are the ideal machines for gases with low molecular weights, high compression ratios, and variable configurations.

Continuous reliability.

They are unaffected by variations in volume, temperature, or pressure – which makes the oil-injected VMY screw compressors from AERZEN ideal for use in discontinuous operation. All units and stages in this series are outfitted with a control carriage for volume flow regulation (gate control). A continuous change in volume streams of between 100% and 20% means an optimal customisation to the operation at hand. Reliable over a vast range of requirements and operating conditions. Low operating costs and reliability are their hallmarks. There are a total of 16 different models available.

Performance and characteristics.

- Technology: units and stages with oil injection
- Volume flow: 233 to 8,910 m³/h
- Negative pressure: -900 mbar; positive pressure: 25 bar (g)
Higher pressures available on request
- Rotors: energy-saving 4+6 profile
- Vi modification based on operating data
- Media: neutral and flammable gases, oil-consistent gas mixtures and process gases, as well as all standard coolants

Intake volume flow Q_1 (m³/h)

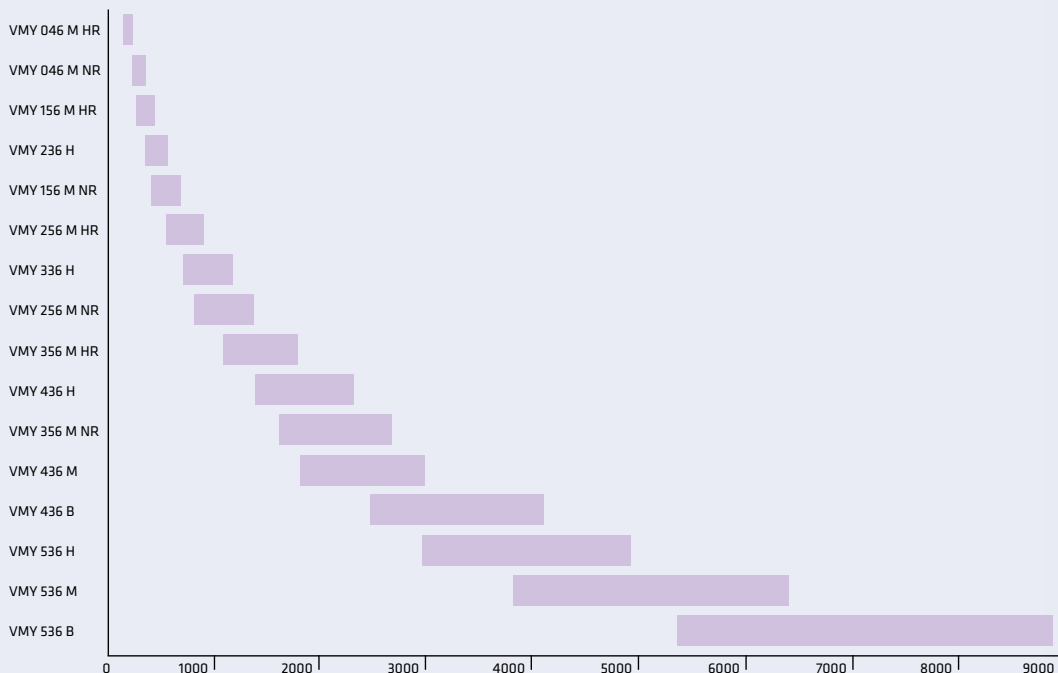

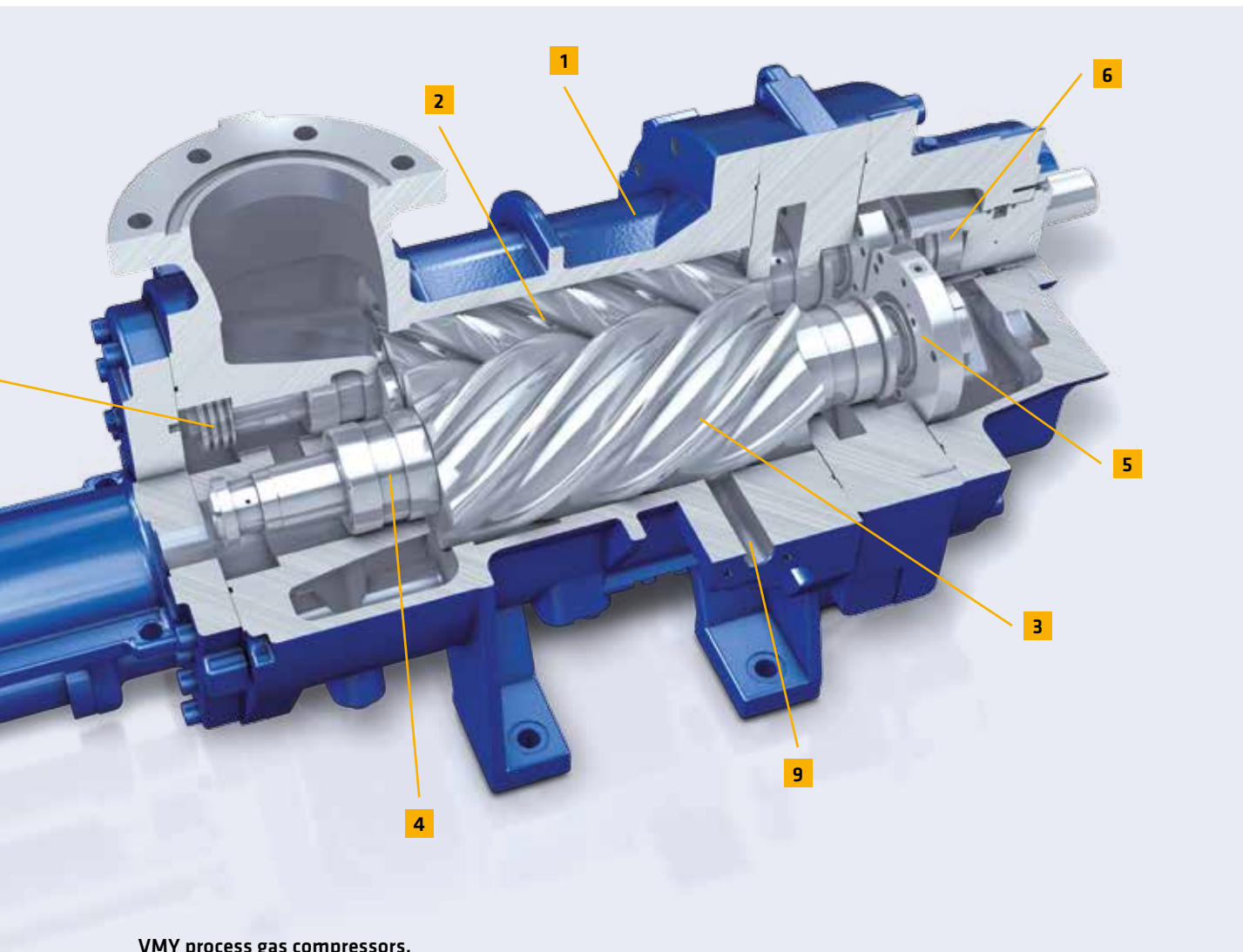

VMY process gas compressors.

- | | | | |
|-----------------------|--------------------------|------------------------------|--------------------------|
| 1 Housing | 4 Radial bearing | 7 Displacement sensor | 10 Balance piston |
| 2 Male rotor | 5 Axial bearing | 8 Vi setting | |
| 3 Female rotor | 6 Mechanical seal | 9 ECO connection | |

GR/GQ PROCESS GAS BLOWERS.

BLOWER POWER FOR SPECIAL REQUIREMENTS.

All AERZEN oil-free process gas blowers have one thing in common: they are robust, high-performance machines. Unaffected by gas contaminants or moisture. Suitable for continuous fluid injection for gas cooling or cleansing. And they can be designed to include a wide range of special materials and seals.

GR process gas blowers.

The 1 or 2 stage blowers can be used for almost all technical gases and gas mixtures. In all branches of industry. They are also ideal for gases with negative intake temperatures down to $-30\text{ }^{\circ}\text{C}$.

- Volume flow: 100 to 50,000 m^3/h
- Negative pressure: -500 mbar; positive pressure: 5,000 mbar (g)
Differential pressure up to 1,500 mbar (max)
- Conveying direction: vertical
- Media: air, oxygen, as well as neutral, toxic, flammable, or corrosive gases or gas mixtures

GQ process gas blowers.

Ideal for use in steel plants for the compression of process, cooling, and seal gas. These blowers are often used as 2-stage units and are up to the most extreme challenges.

- Volume flow: 15,000 to 100,000 m^3/h
- Negative pressure: -500 mbar; positive pressure: 5,000 mbar (g)
Differential pressure up to 1,500 mbar max
- Conveying direction: horizontal
- Media: air, as well as neutral, toxic, flammable, or corrosive gases or gas mixtures

GR intake volume flow Q_1 (m^3/h)



GQ intake volume flow Q_1 (m^3/h)

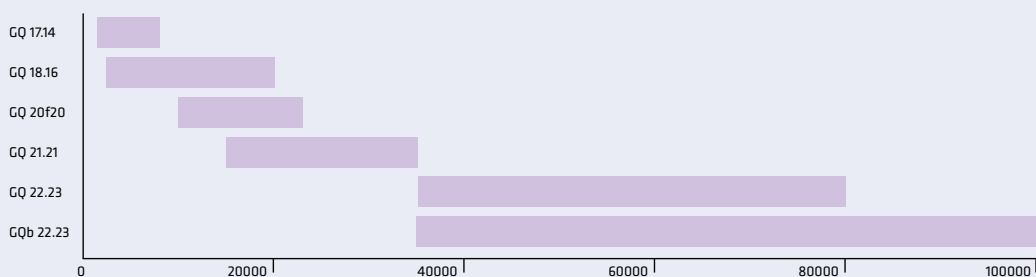

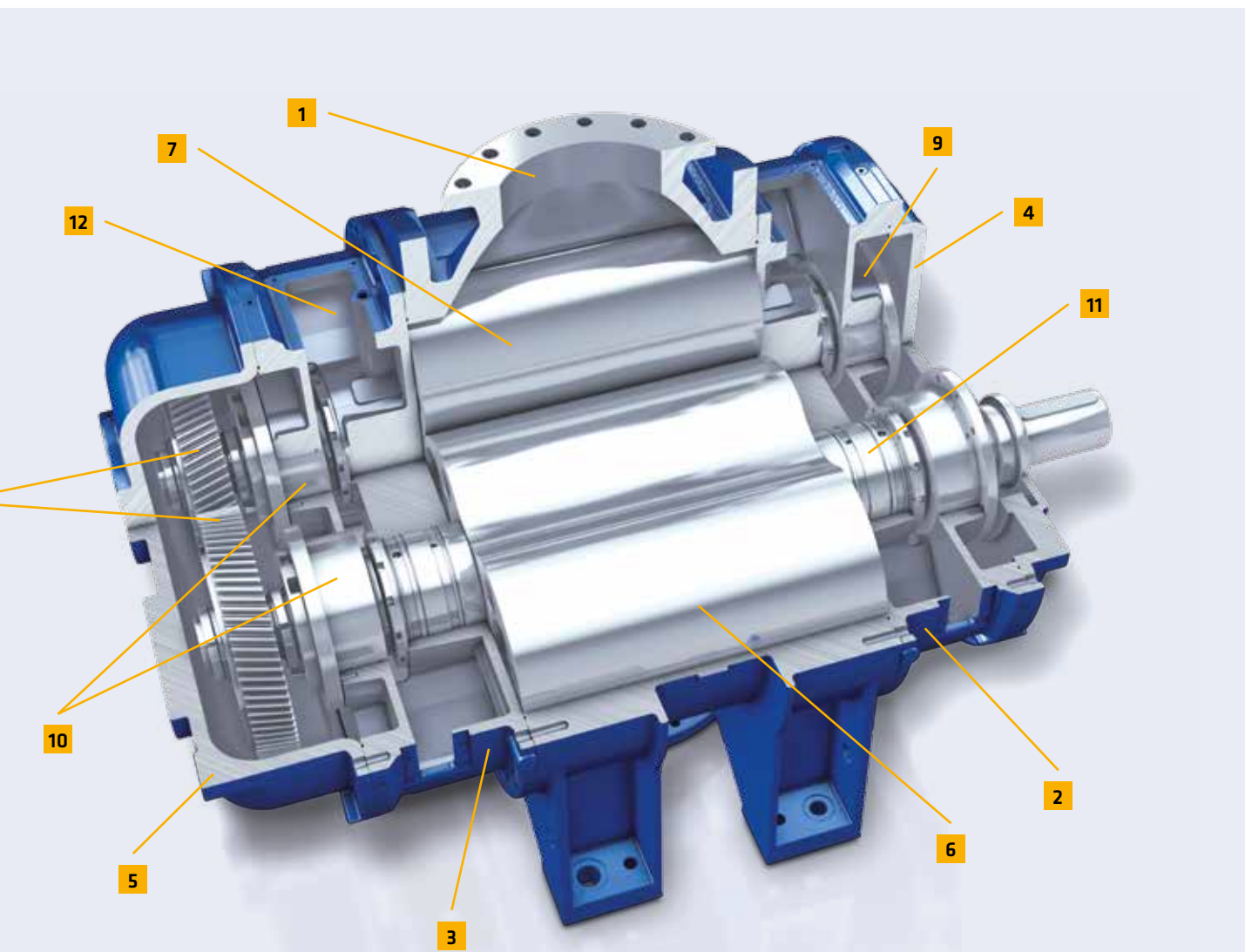

GR process gas blowers.

- | | | | |
|------------------------|---------------------------------|---------------------------------|----------------------------------|
| 1 Housing | 4 Housing lid | 7 Rotary pistons with NW | 10 Fixed bearings |
| 2 Side plate AS | 5 Wheel case | 8 Timing gears | 11 Conveying chamber seal |
| 3 Side plate RS | 6 Rotary pistons with AW | 9 Floating bearing | 12 Neutral chamber |

GM ... DZ HIGH-PRESSURE BLOWERS. FOR SAFETY IN DEMANDING SITUATIONS.

Special solutions for special applications. For cases when prepressurised media exit the pipes. And pressure differentials of up to 2,000 mbar are required. This is what the high-pressure blowers from AERZEN were designed to handle. For oil-free conveyance in the chemical and many other industries.

Pressure-stable up to PN 25.

The direct-drive GM ... dz blowers from AERZEN are high-performance machines. 1 or 2 stage design, with separate pressurised oil lubrication for the oil-free transport and compression of air, neutral gases, and gas mixtures. Highly advanced and extremely robust Roots-type products. Available in a wide range of special materials and seals, such as stainless steel or as acetylene boosters according to TRAC norms.

Performance and characteristics.

- Volume flow: 60 to 6,000 m³/h
- Positive pressure: 25 mbar (g)
Differential pressure up to 2,000 mbar max
- Positive pressure: up to PN 25
- Conveying direction: vertical
- Media: air and neutral gases, gas mixtures

Intake volume flow Q_1 (m³/h)

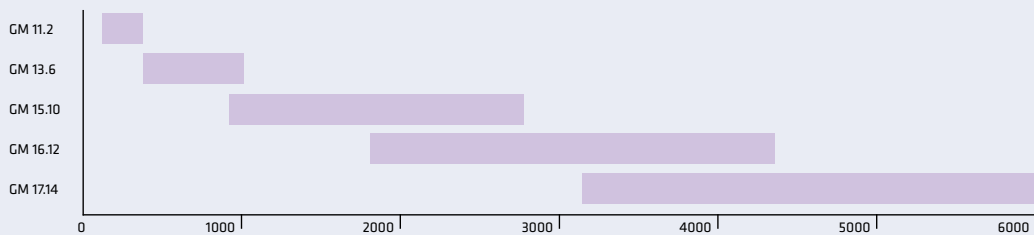

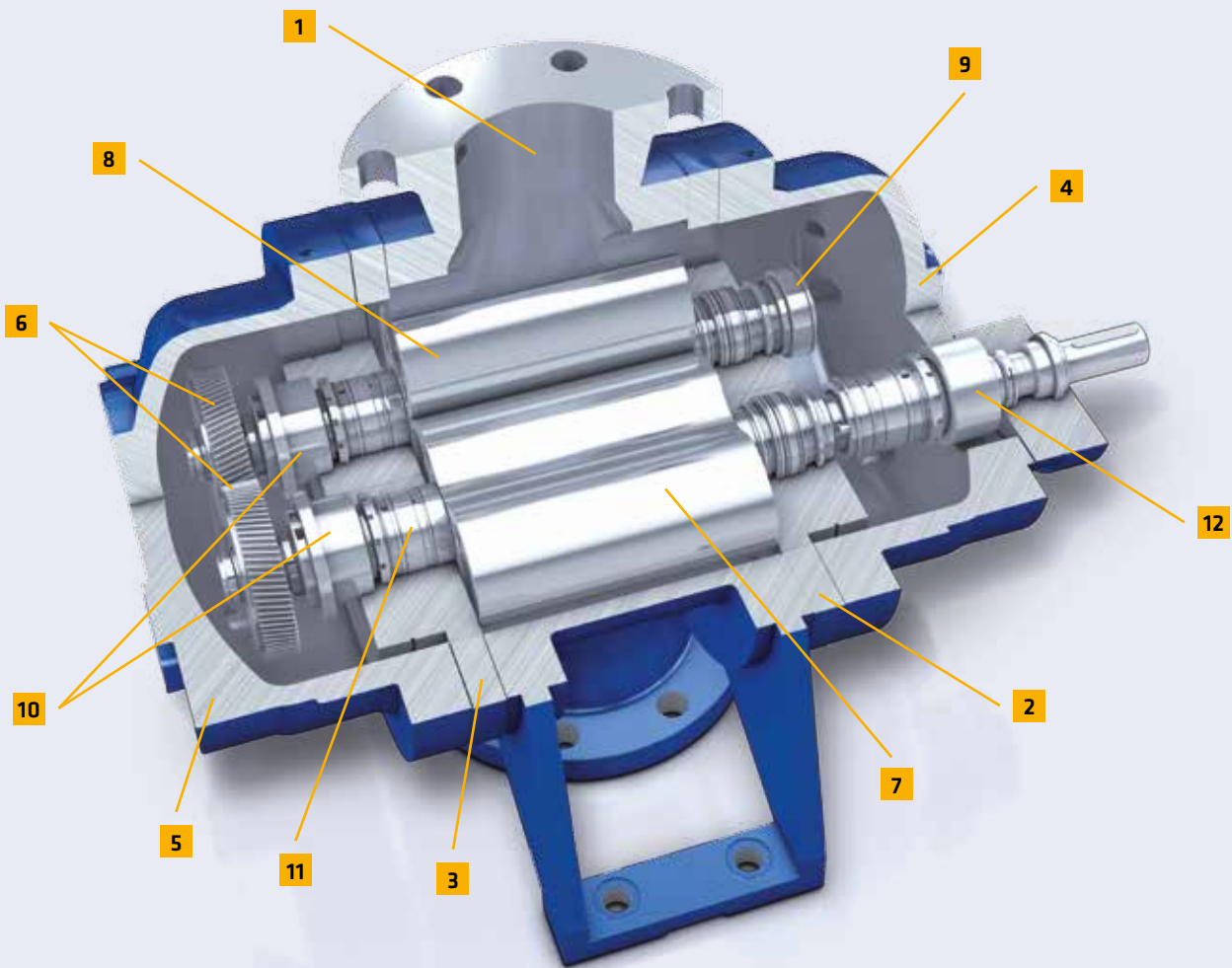

GM ... dz process gas compressors.

- | | | | |
|--------------------------------|-----------------------|---|--------------------------------------|
| 1 Housing | 4 Housing lid | 7 Rotary piston with drive shaft | 10 Fixed bearings |
| 2 Side plate drive side | 5 Wheel case | 8 Rotary piston with secondary shaft | 11 Piston ring labyrinth seal |
| 3 Side plate gear side | 6 Timing gears | 9 Floating bearing | 12 Double mechanical seal |

PRODUCTS.

A WIDE VARIETY FOR INDIVIDUALISED APPLICATIONS.

ROTARY LOBE BLOWERS



Model GR



Model GQ

Areas of particular expertise

Oil & gas upstream

Oil & gas midstream

Refineries

Petrochemical industry

Other industrial applications

Pharmaceutical industry

Applications

- Gas boost

- Gas boost
- Chemical processes
- Regeneration processes

- Gas boost for lime kilns, steel, coking plants
- Coke oven gas (COG)
- Blast furnace gas (BFG)
- Natural gas (NG)

- Product conveyance

- Gas boost for COG, BFG, CG
- Coke oven gas
- Blast furnace gas
- Cooling gas

Performance data

- Volume flow approx. 100 – 50,000 m³/h
- Negative pressure -500 mbar
Positive pressure 5,000 mbar (g)
- Delta P max 1,500 mbar

- Volume flow approx. 15,000 – 100,000 m³/h
- Negative pressure -500 mbar
Positive pressure 5,000 mbar (g)
- Delta P max 1,500 mbar

Models

- GR 12.4 – 21.22

- GQ 17.14 – 22.23



Model GM ... dz

- Nitrogen boost
- Acetylene boost (TRAC)

- Cooling loops
- Kiln pressure test bed
- Ammonia boosting

- Volume flow approx. 60 – 6,000 m³/h
- Positive pressure 25 bar (g) if the medium is prepressurised
- Delta P max 2,000 mbar

- GM ... d
- GM ... dz

OIL-FREE SCREW COMPRESSORS



Model VRa

- Associated gas
- Fuel gas boosting (gas turbine)

- H₂ and CH gas mixtures, flare/tail gas, butane and propane recovery

- CH gas mixture boosting

- Butadiene, lime kiln gas boosting, styrene, ammonia boosting
- Methyl chloride boosting

- Coke oven gas boost

- Volume flow approx. 650 - 120,000 m³/h
- Negative pressure -900 mbar
- Positive pressure 52 bar (g)

- VRa 137 – 736 L
- VRa 136 – 1037 M
- VRa 136 – 736 S
- VRa 236 – 336 H

OIL-INJECTED SCREW COMPRESSORS



Model VMY .36



Model VMY .56/046

- Gas gathering onshore, offshore

- Natural gas compression
- Fuel gas boosting (gas turbine)

- H₂ and CH gas mixtures, flare/tail gas, butane and propane recovery

- LNG, LPG, cryogenic, ammonia boosting

- Gas gathering onshore, offshore

- Natural gas compression
- Fuel gas boosting (gas turbine)

- H₂ and CH gas mixtures, flare/tail gas, butane and propane recovery

- BOG (Ethylene)
- Turbine fuel gas

- LNG, LPG, cryogenic, ammonia boosting

- Volume flow approx. 700 – 10,000 m³/h
- Negative pressure -999 mbar
- Positive pressure 25 bar (g)

- Volume flow approx. 444 – 2,700 m³/h
- Positive pressure 25 bar (g)

- VMY 236 – 536

- VMY 046/156/256/356

AERZEN process gas compressors and blowers have proven themselves in over 10,000 units installed the world over. What are the decisive factors? Extremely long service life. Sharp focus on efficiency criteria. And also this: the unusually broad portfolio of solutions, including modifications, accessories and special developments to ensure they meet the every possible process requirement.



The engineering and production centre at AERZEN, where high-performance, high-end solutions for the process gas and coolant industries are born.

Focus on special requirements.

AERZEN is a pioneer in compressor technology. In many areas we are the market leader. With unique technological advantages. With superior quality and high efficiency. Our product portfolio for the process gas and coolant industries? A broad spectrum of specialised blowers and compressors. High-end machines with a wide variety of designs, sizes, and special features. Configured so they meet all relevant international regulations, building codes, and specifications in a wide variety of industrial branches and certification bodies. Including ASME, API, TEMA, ANSI, Ex and DIN, the European Pressure Equipment Directive (PED), as well as safety regulations for electrical installations such as DIN, EN, NEMA, IEC und ATEX.

Rightsized for the process.

Energy efficiency is one of the main demands on today's compressor technology. Not surprising when you consider that it can make up as much as 80% of the lifecycle costs of compressor installations. Reducing energy consumption is one of the main goals of AERZEN's R&D department. All our blowers and compressors are radically flow optimised. Carefully selected transmission variants are just as important to increasing efficiency as innovative component developments. But the decisive factor in reducing energy consumption is this: every compressor and blower unit from AERZEN is tailored to the individual requirements of our customers and their processes. Rightsized and thus especially efficient.

SERVICE AROUND THE WORLD. SERVICES FOR GLOBAL INDUSTRIES.

The best kind of process gas and coolant installations are the kind you do not notice. Because they run for 20, 25, 30 years. This is what we provide. With highly specialised service teams in Germany, in Europe, in over 100 countries on our planet. This is how we can secure your investment, productivity, and decisive advantage in global competition.

AERZEN OEM expertise is at your service - anytime, anywhere in the world



AERZEN on-site service.

Wherever AERZEN machines are, the service teams from our Process Gas Division are available. The world over. How can we do that? By shortening the distance to our customers. The PGD has three regional service centres in Germany, Hungary, and the USA. Their experts work in all global AERZEN branch offices so they can be there whenever and wherever you need them.

As multifaceted as our customers.

The extraordinarily customer-oriented PGD service philosophy? It begins with the friendliness of our colleagues, but certainly does not end with on-site training. Included in the portfolio:

exchange stages, tailor-made service kits, machine diagnosis, process modifications, energy-savings studies, technological enhancements, acoustic optimisation, replacement parts, and a large selection of rental machines.

Packaging and shipment are also an important part of our service. The process gas and coolant compressors can be configured and packaged in Germany, Hungary, or the USA. Tailored precisely to the needs of our customers. Combining AERZEN's immense experience and engineering resources with the flexibility of the Process Gas Division in project management and on-site packaging.



Getting in touch the world over

There are 2,000 people working for AERZEN. On all continents. With six sales offices in Germany alone. And 43 affiliates in over 100 countries. This is how we shorten the distance to you our customers – so we can be there when you need us.

Give us a call:

+49 5154 81-0

Service Hotline

We are there for you – even outside of office hours. Use the direct line to AERZEN via our regional service hotlines:

+49 171 3511834

Customer Net

Where can you learn more about our company and the leading compressor technologies coming out of Aerzen? Simple: the Customer Net link on our homepage. We've put everything there that you need to know.

www.aerzen.com



AERZEN. Compression as success principle.

AERZEN began life in 1864 as Aerzener Maschinenfabrik. In 1868 we built Europe's first rotary lobe blower. The first Turbo compressors followed in 1911, the first screw compressor in 1943, and in 2010 the world's first rotary lobe compressor unit. Innovations "made by AERZEN" keep driving the development of compressor technology forward. Today, AERZEN is among the world's oldest and most significant manufacturers of rotary lobe blowers, rotary lobe compressors, rotary lobe meters, screw compressors, and Turbo blowers. And among the undisputed market leaders in many areas of application.

More than 2,000 experienced employees in over 40 affiliates the world over are working at full speed to advance compressor technology. Their technological expertise, our international network of experts, and constant feedback from our clients form the basis for our success. Products and services from AERZEN are setting standards when it comes to reliability, lasting value, and efficiency. Go ahead: challenge us!

Aerzener Maschinenfabrik GmbH
Reherweg 28 – 31855 Aerzen / Germany
Telephone: +49 5154 81-0 – Fax: +49 5154 81-9191
info@aerzener.de – www.aerzen.com



AERZEN
EXPECT PERFORMANCE